

WELCOME— It is with a great deal of pleasure that we welcome you back and to the second installment of YORK TALK, the newsletter from the YORK Group.

It goes without saying that the global markets have been what is probably best referred to as unpredictable these last few months and most employers have made additional efforts to seek out opportunities from business channels not explored previously as “thinking outside the box” becomes an almost mandatory operational business process necessary for ongoing success.

Suppliers have been making repeated adjustments to stock levels to cater for the differing level of business activities around the globe and this has impacted in places on the availability of stocks and delivery times.

It is most certainly not all doom and gloom though. YORK has seen a number of positive outcomes as a result of the addition of both the new sales staff (yes, that's right we have added to the team) and also from changes made at the operational level where we have been able to improve on manufacturing efficiencies.

There have been challenges presented to all parts of our business as we meet the growing pains head on and through persistence and determination we have overcome them.

We have seen customers adapt their existing manufacturing lines and business models to meet the changing markets demands and we have seen growth from some markets that were expected to remain under pressure for some time.

The availability of suitable finance has proven to be a barrier in some markets and this has certainly impacted on the level of CAPEX purchases expected to be made.

You will see as you turn the pages that Tata have launched their World Truck project and that we have also added a small section called “Product Info”.

We hope that this brings to your attention some of the product lines we have available from the group that to your attention that you may not be fully aware of and that together we can open new doors and explore new opportunities.

Again, we thank you for your patronage and trust that through YORK TALK you will be better acquainted with both the products and the people in the YORK family.

Regards M.W.Boon — Editor



WA Show—Perth 2009.

YORK recently exhibited at the 2009 Perth Truck & Trailer show. The bi-annual event was held in the Perth Convention centre (July 24th - 26th) and now utilises all 6 pavilions at the venue. Well supported by suppliers and visitors alike the 3 days showcased a range of products and brands from all areas of the industry, accessory displays, official functions, entertainment and there was something to keep the whole family smiling.

The last show attracted crowds of over 8,000 and presented many opportunities for networking and generated many sales and leads.

Comments and feedback from all parties involved were extremely upbeat considering the global economic position but everyone in the West is looking forward to a positive year.



Staff Relocation



Albert Van Der Poel has officially departed South Africa to commence his new role as the Group Applications & Service Manager.

Albert will operate from the YORK Head office located in Pioneer Road, Singapore.

We wish Albert and his family the best of luck with their move and in his new position.

The adventures that will unfold in his new role as the business continues to grow globally will present many exciting challenges.

The responsibility of the South African market and surrounding regions has been transferred into the very capable hands of Willem Brits and we look forward to continued growth for YORK.

Remember

The pain of poor quality and poor service is remembered long after the joy of a low price is forgotten.

DEMAND "GENUINE YORK"
Service Parts

Australia—Queensland Truck & Machinery Show



Shown above L to R, Mr PV Balasubramaniam, Dr Jamshed J Irani, Mr Sudhir Deoras and Mark Boon

The 2009 Queensland Truck and Machinery Show held in May hosted some big names from the TATA Group.

Director Dr Jamshed J Irani, who is renowned throughout the iron and steel industry and was CEO of the TATA Iron and Steel Company Ltd for nearly a decade, before retiring in 2001 and taking up his current position; Director and CEO of YORK Transport Equipment (Asia) Pte Ltd Mr PV Balasubramaniam; and Managing Director of TRF Limited Mr Sudhir Deoras all flew in from India to be in Brisbane.

YORK took the opportunity to have the groups Country managers visit the show to provide some exposure to the trailer options and configurations and technology Australia can provide. YORK took the opportunity to visit with a number of local trailer manufactures also. The show proved to be a great success for YORK with many positive leads obtained for follow up.

At this year's show, YORK launched its brand new Maintenance Free Long Life Axle (MFL), purposely engineered to suit the Australian market. Soon to follow is York's new 25 tonne suspension and 25 tonne axle.



YORKERS R&R—Prawning

Yorkers gathered late in June for a Prawning competition organized by the YTEA Social Committee. The event was organized to "De-Stress" Yorkers from their typical work routine and to promote healthy team interaction.

Bottle Tree park was the venue for the event attended by thirty five enthusiastic Yorkers. The Yorkers were split into teams of four with attractive prizes up for grabs for two teams with the highest catch. The event was a test of skill, patience and of course some luck.

The event spanning a few hours saw some teams get off to flying starts while others were not so lucky. A little like the story about the Tortoise and the Haire. The teams persevered and the event concluded in a very close finish. The spicy curry puffs and prawn crackers added flavour to the event. Prizes for the winners were presented by the YORK Group CFO, Mr.Poh Beng.



Did YOU Know?

York has an extensive product offering.

Trailer axles (various track lengths and wheel fixings are available)

Trailer—Mechanical Suspension Systems (Including 75 mm, 75/90 mm and HD 90 mm)

Trailer—Air Suspension Systems (Fixed beam and parabolic trailing arm designs)

Trailer - HD Suspension Systems (Single point and Walking Beam)

Brake Kits (ABS, EBS etc)

Landing Gear

Wheel Rims

Twist locks

Fifth Wheels

King Pins

Pneumatic Kits

& **MUCH** more

TATA Motors—World Truck



TATA Motors launched their World Truck series in June 2009. This is a program that was started about a decade ago in 2000 by TATA Motors to bridge the gap between the trucks available in many of the developed countries and the trucks currently available and produced in India.

The mission was to clearly modernize road transportation in India and effectively compete with global players in India and abroad. TATA Motors is planning to sell all world trucks complete with trailers as a package offering to suit the customers application.

YORK is proud to be partner in the trailer program attached to this project and YORK axles and suspension sets are used in the trailers being sold along with these world trucks.

This is a 5" round axle with a 19mm wall thickness complete with a braking system specially developed by TATA Motors to meet their requirements.

Other product to be fitted to these trailers includes YORK 75/90 10leaf mechanical suspension set, YORK YT-28A-2-SF landing gear, a 2" demountable king pin assembly and twist locks. The picture shown here (see above) is just one of the applications TATA Motors proposes to produce Truck models for to as part of the World Truck project.

Australia—J Smith & Sons



A valued and long standing customer of YTEM is J. Smith & Sons. They are a 109 year old Gympie based company, located in Queensland who manufacture a wide range of trailers for the specialised transport tasks within Australia and overseas.

The trailers shown here (see left) operate in a Quad axle format and are fitted with 315/80 R22.5 tyres running at 18t/axle. For operation on rougher ground or with uneven surface J Smith & Sons build a Tri-axle format with 1400 R25 tyres operating at 25t/axle.

J Smith & Sons manufacture a range of trailers including but not limited to heavy-duty off-highway trailers for the coal and hard rock mining industries. These include bottom-dump, side-tipping and rear-tipping trailers up to 115 tones capacity per trailer. Car carriers, tipping container skels, low loaders, trailers for sugar cane and raw sugar, roll-on/roll-off transfer trailers between road and rail for sugar cane wagons and 'SMITH' super-lift trailers for cane haulage and the waste industry. & other unique trailers, all tailor made to perform specific transport tasks.

J Smith & Sons employ a competent team of six engineers, who utilise 2-D CAD, 3-D modeling and finite element analysis to optimise the design of all 'SMITH' equipment. They specialise in the design and manufacture of "out of dimension: and "high payload" semi-trailers for bulk commodities. They can be contacted via their company web site at www.smithson.com.au

R08 (Row of Eight)

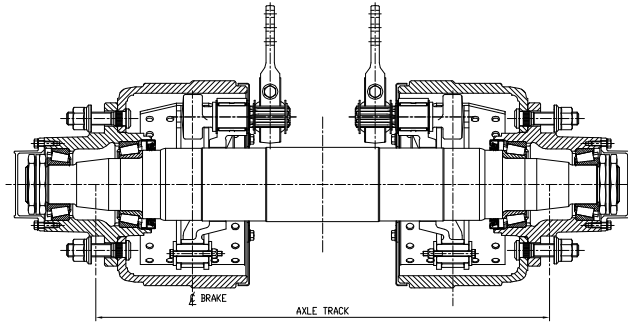

Typical YORK R08,
10 x 225 pcd wheel
end assembly.
(See left)

YORK manufactures an axle product that is used extensively the world over, for specialist low bed, widening deck trailers used in applications such as house removals, machinery, plant and equipment transfers and mining. With YORK R08 axles fitted these trailers with their variable deck heights can typically widen either mechanically or hydraulically from app 2.5m out to 3.5 to 4.5m, depending on the trailer design and the markets legislative limitations.

The R08 has become a generic name and is known as such as due to the trailers fitted with these axles generally having multiple axles per trailer and each row / module fitted with 8 wheel end assemblies. Generally and for heavy haulage applications, trailer builders install hydraulic trailing arm suspension systems (often their own unique designs), both fixed and steerable in their configurations for the various applications, road speeds and operating environments.

YORK R08 axles are available with either 15" dual spider wheel end assemblies or the more common 10x225 pcd steel hub configuration. 15" dual spider axles can suit either a 15" tube type tyre with 15" demountable rims or a 17.5" tubeless tyre with 17.5" demountable rims. 10x225 pcd axles can be supplied to suit steel or alloy wheel fitment. These axles can suit either a 15" tube type tyre with 15" – 10x225 pcd rim or a 16" tube type tyre with 16" – 10x225 pcd rim or a 17.5" tubeless tyre with 17.5" – 10x225 pcd rim. The YORK R08 axles can have optional track lengths, but typical tracks include a standard range from 720mm to app 1000mm. Axles are made from a high alloy seamless tube with a 16mm beam thickness as standard. Axles are available with either an ADR 38 (Australian Design Rule) compliant 311x178 brake size (2783/2953 model) or a narrower 311x127 brake size (2954 model). 2783/2953 and 2954 axles have a nominal capacity of 10 tonne and 9 tonne respectively. 'P' type brake shoes are used with riveted asbestos free linings. There are two brake drum size options in 2954 axles, including a narrower drum width for increased inside drum clearance.

Induction hardened 1 1/2" x 10 spine short camshafts and plated cam rollers are used for longer life and smoother operation. The camshafts have an open cam design and are fitted with a bolt-on cam roller retainers and with standard camshaft o-rings, washers and circlips for positive security. Vesconite camshaft bushes are used to provide a longer service life. Bolt-on type anchor pins are used for positive locking via a bolt, nut and washer and for ease of assembly. A 15" axle brake return spring ensures that there is constant contact between the shoe, cam roller and camshaft. The brake spider cam bores are fitted with grease nipples to ensure that the cam and cam shaft bushes are able to be lubricated.

Industry standard TN tapered roller bearings and hub seals are used for ease of servicing. York standard two piece hardened spindle nuts, lock and lock tab washers are used for a positive locking device, and ease of bearing adjustment and servicing. Bolt-on grease filled hubcaps are used for ease of assembly. Dust cover backing plates are optional to further protect from an ingress of foreign materials. Brake boosters, brake chamber brackets and actuators are not fitted as standard as trailer builders tend to install remote mount actuators to suit their individual trailers designs.

MFL Axles — (Maintenance Free Longlife)

YORK Transport Equipment has developed a new variant to their existing axle product line for applications of up to 11Tonnes.

The NEW axle is referred to as the MFL Axle.

MFL stands for “Maintenance Free Long life”.

The YORK MFL is available as both a drum brake and disc brake axle variant and is ADR compliant

The YORK MFL axles have a controlled assembly process in place to ensure improved operational performance and the bearing pairs are pre packaged in a closed, dust free operating environment to achieve zero contamination. The YORK MFL axles are designed with a double seal configuration to protect the bearing package from potential contamination from less than ideal operating conditions.

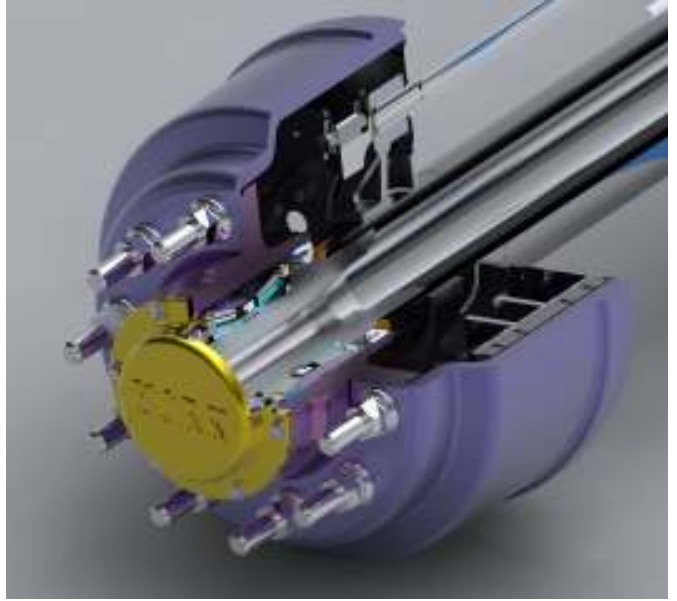

The YORK MFL axles have a single spindle / bearing locking nut that is torqued to a pre determined setting. Currently available as either a 10 x 285.75 pcd Drum brake (420 x 180) or 10 x 285.75 pcd disc brake (17” Disc Wabco twin caliper disc brake (PAN22 model)).

These products are supported by YORK for three (3) years or 500,000Kms. Go ahead, make the change,. Switch to YORK’s MFL axle and reduce your trailers maintenance costs.

Indonesia—PT Aweco

YORK has successfully partnered with Trailer manufacturer PT Aweco Indosteel Persaka to introduce Air Suspension to Indonesia for use in a Pertamina LPG tanker. This is the first LPG tanker in Indonesia to use air suspension in lieu of mechanical suspensions which to date have been the standard. The hemispherical head design has the highest strength of any head type for pressure vessels.



The pressure is equally distributed across the surface of the head due to its single radius. By using the hemispherical heads PT Aweco Indosteel Persaka LPG tanks are guaranteed to have a higher strength and less tare weight compared to the traditional ellipsoidal heads designs.

PT Aweco Indosteel Persaka is the first company in Indonesia to introduce hemispherical heads for LPG transport and storage tanks. The YORK TecAir 1 air suspension product was chosen as the most suitable product offering to suit the customers application and operating environment.

SERVICE



TAPERED BUSHES

Many people assume that rubber grease is suitable for the installation of all things rubber and as such for the tapered rubber bushes in mechanical suspensions.

In fact rubber grease is not suitable. It remains in suspension (slippery) for some time after the assembly process and does not allow the rubber bushes to remain seated when in operation.

A simple mixture of soap and water is actually the most suitable lubricant.

It remains slippery for long enough to undertake the installation process and shortly thereafter dries out, ensuring all of the components are seated in place so they perform as they were designed.

Simply add a few drops of liquid soap to a small quantity of water for easy installation and you will maximize your tapered bush service life.

YORK—YTE75/90 Mechanical Suspension Systems

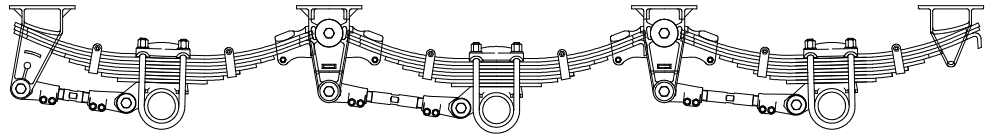

YORK is renowned across the globe for its reliable and proven mechanical suspension systems. The models and options vary obviously, depending on the country and end user applications but one of the most popular products for the group is the YORK YTE75/90. It was developed and engineered by YORK for the trailer market with 12 to 15 Ton applications. They have been used by YORK customers for more than a decade for both on and off highway application.

High resistance wear pads have been introduced to enhance the products in-service reliability. Hangers and equalizers are manufactured using the proven investment casting process with high strength steel and YORK maintains consistent product quality with dimension stability and good surface finishes.

The torque arms are connected through replaceable tapered poly bushes, spring packs are available with 10 leaf configurations and have all undergone validation tests as per SAE recommendations and GB standards to prove their reliability and performance. Leaf spring surfaces are shot peened to induce compressive stress and improve the product life during operation. Springs are then surface treated to enhance their life cycle.

The YORK YTE 75/90 mechanical suspension system is available for various applications and as such can be assembled to meet the differing wheel centers, axle sections and ride height requirements.

Equalizers are grease lubricated and swing on bronze bushes. To minimize the maintenance practices, Vesconite bushes can be used as an option where no greasing is required or the operations makes constant lubrication unfavorable.

The simple casting design allows for easy welding to trailer chassis and the axle alignment can be carried out by adjusting the variable threaded torque arm assemblies which are fitted.

Thailand—Nonthaburi

The Thai Beverage (ThaiBev) Company, one of the largest beverage alcohol companies in South East Asia runs on YORK. Thai Beverage owns and distributes a number of significant and renowned brands including Chang Beer, Mekhong whiskey and Sang Som rum.



This trailer is the 1st of 100 trailers currently under construction at the Nonthaburi Trailer Truck & Bus Company Ltd.

All trailers will be fitted with YORK axles, YORK mechanical suspension systems and YORK Landing Gears.

The project is set to be completed by the 2009 year end.

Ivory Coast—Lassire Industries



Lassire Industries, based in Abidjan, was founded over 50 years ago, starting life as a small general steel fabrication workshop. Over time, the owners of the company saw that there was a need in the market for body-building for fitment to rigid trucks as well as general fabrication and steelwork.

This progressed to building agricultural trailers (see below) and, eventually, road trailers (see above) . Approximately 10 years ago, Lassire were appointed the YORK dealer and have become the leading trailer manufacturer in West Africa.

Lassire manufactures a very impressive range of trailers including skeletal container carriers, steel box cargo trailers, tippers, low-beds, curtain-siders, tankers etc. In fact, if there is a requirement, Lassire can supply it; all on YORK axles. Driven by their Director General, Frederick Lanes, Lassire have an excellent reputation for quality. But Frederick realised that to grow the company they had to be more than just a manufacturer. As a result, Lassire also perform full servicing of trailers for their customers and, of course, have a large spare parts division to ensure complete back-up for their product.

They are now fully approved suppliers to companies such as Shell, BP, Mobil and Maerskline and for companies such as these to source locally rather than import from Europe demonstrates just how far Lassire have come from their humble beginning 50 years ago.

Today, The Ivory Coast is thankfully no longer associated with ivory, rather it is known as one of the leading producers of cocoa. Needless to say, many of Lassire's customers are in the cocoa industry; mainly using steel bodied, box trailers to transport raw cocoa pods from forest to factory or finished goods from factory to the port for export. Since these trailers are operating both on and off road, Lassire use the York 2 x 16t Dreadnought bogie axle for this application.



Not so well known is the fact that sugar cane is a major crop in the area. Anyone in the sugar cane industry will know that sugar cane trailers work virtually non-stop during the harvest season and have to cope with the most arduous of conditions in the sugar cane fields.

For this application, Lassire use the YORK Heavy duty YTE90 tandem suspension fitted with 8021 series axles that have a 20t capacity. They have proven to be an excellent workhorse in this market.



Mr Arindam Ghorai joined YORK in September as Chief Strategic Sourcing.

Arindam holds a Bachelor of Technical (Metallurgy) from the Bengal Engineering College, Sibpur and a Masters in Technology from IIT, Mumbai.

Arindam comes to us with 13 years of experience in strategic sourcing in the automotive industry. He can be contacted via the Jamshedpur office on +91 657 227 1286 or email at



Mr Pankaj Manohar Shenoy joined us in August as Chief Sales & Distribution in the Mumbai office. Pankaj holds a Bachelor of Engineering (Mechanical) from the Manipal Institute of Technology.

Pankaj comes to us with 25 years of experience in Sales & Marketing in the automotive Industry and in the last couple of years from the trailer / axle industry. He can be contacted via the Mumbai office on +91 22 2261 6853 or email at

Pankaj.shenoy@yorktpt.com.sg

EVENTS Calendar

2009 OCT (13—15) TRANSOMAN — Transport Shipping & Logistics Show.

TRANSOMAN is the Sultanate's first comprehensive event providing access to cutting-edge solutions, services and infrastructure especially designed for the transport, shipping, aviation and logistics industry. TRANSOMAN is not just an exhibition. It is a forum to discuss industry issues; discover the latest trends; connect and do business with various suppliers and service providers in the air, road, rail, shipping, customs, cargo and logistics businesses, connecting Oman, the rest of the region and beyond.

For more information go to www.trans-oman.com

2009 NOV (15—17) ATA/ARTSA TMC (Technical & Maintenance Conference), Australia.

Held this year at the new location of Silverwater Resort, Phillip Island, Victoria the 2009 TMC will improve on its long standing traditions and continue to bring a multi streamed program via technical presentations and practical demonstrations direct to fleet and end users. The once a year opportunity to meet with suppliers and technical experts in their field should not be missed.

For more information go to www.atatruck.net.au

2010 JAN (5-11) The 10th Auto Expo, Pragati Maida, New Delhi, India.

The 10th Auto Expo is the complete automotive show in this part of the world, organized jointly by the Automotive Component Manufacturers Association of India (ACMA), Confederation of Indian Industry (CII) and the Society of Indian Automobile Manufacturers (SIAM).

For more information go to www.autoexpo.in

2010 MAR (18—20) International Truck, Trailer & Equipment Show, Melbourne, Australia.

Held at the renowned Melbourne Show grounds, the 2010 show will feature all Truck Manufacturers, the largest collection of Trailer Manufacturers ever assembled in Australia and all of the ancillary and related component equipment suppliers.

For more information go to www.trucktrailershow.com

YORK Contacts

Singapore

HEAD OFFICE

York Transport Equipment (ASIA) Pte. Ltd.

Corporate & Marketing

122 Pioneer Road, Singapore 639583

Tel: (65) 6897 8525 Fax: (65) 6897 8231

Email: enquiry@yorktpt.com.sg

Website: www.yorktransport.com.sg

Operations

5 Tuas Ave 6, Singapore 639295

Tel: (65) 6861 0577 Fax: (65) 6861 4045

South Africa

YTE Transport Equipment (S.A.) (Pty) Ltd.

Tel: (27) 82 3764552

Email: wbrits@yorktpt.com.sg

Thailand

York Sales (Thailand) Co. Ltd.

2101 M.1 Old Railway Road. Samrong Nua, Muang, Samutprakam 10270 Thailand.

Tel: (66) 2 743 5091 Fax: (66) 2 173 7300

Email: yorkth@ksc.th.com

China

Qingdao YTE Special Products C. Ltd.

No. 18 Huishui Road, Licang District, Qingdao China 266101.

Tel: (86) 532 8092 3091 Fax: (86) 532 9082 3080

Email: edwin@yte-casting.com

Australia

York Transport Equipment (Australia) Pty. Ltd.

13 Monterey Road, Dandenong, Victoria 3175 Australia

Tel: (61) 3 9790 200 Fax: (61) 3 9790 2020

Email: sales@yorktransport.com.au

Website: www.yorktransport.com.au

UK

YTE Special Products.

5 Scott Close, Market Harborough, Leicestershire LE16 7LN
United Kingdom.

Tel: (44) 1858 434425 Fax: (44) 1858 465125

Email: tony@extrauk.com

India

York Transport Equipment (ASIA) Pte. Ltd.

MAGNET House, Ground Floor, Narottam Morarji Marg, BALLARD ESTATE, MUMBAI—400001, Maharashtra, India.

Tel: (91) 22 2261 6853 Fax: (91) 22 2261 4085

Email: jvnrao@yorktpt.com.sg