

YORK TALK

THE YORK TRANSPORT EQUIPMENT GROUP NEWSLETTER

ISSUE Q1 2013

A YEAR TO BE PROUD OF

By any measure, 2012 has been a tough year for the world economy. Yet York can be proud of the way we have cemented our position as a world leader in the transport industry.

For York, the biggest news in 2012 was Tata's completion of its purchase of York Transport Equipment. TRF Ltd, a Tata Enterprise, purchased 51 per cent of the York business back in 2007 as a sign of faith in the worldwide potential of York's axles and suspensions. The May 2012 buyout of the remaining 49% shareholding made York a Tata Enterprise – and brought with it a goal of leading the marketplace. For Tata, it was simply a matter of taking the established and trusted brand of York and making it even better using Tata's vast experience in the automotive industry.

In essence, the driving force of Tata's acquisition was the quality of our core products, which saw York become Australia's first ADR (Australian Design Rules) certified axle. York's 'Road Friendly Suspension' certified products remain in constant demand and we are in fact well known for our wide range of axles tailored for many countries and markets.

In 2012 York's versatility was on display with the fabricated version of our popular YTE 75 for 12T applications. The next step is the introduction of a new series of 'Global Products' with the flexibility for application in most countries. Of course, all of these new products come with new features and technological superiority.

Other exciting product developments in 2012 were centred on the resources sector where

York performs strongly. For example, York's new Reliable 25 tonne mechanical suspension further strengthened York's dominance in the heavy-duty mining sector. York will also shortly release our new 25 Tonne axle to match the suspension performance, encompassing 460 x 177 dia brakes and large M27 dia wheel studs and a unique lubrication system which promises to significantly reduce downtime in this critical heavy-duty sector.

This year, I was also impressed with the way in which York's commitment to new product development resulted in the popular Tecair suspension being fitted to square axles. Our customers were particularly pleased to learn that York's square axles support the Tecair suspension systems just as well as standard mechanical suspensions. At the heart of the new variant is a compact spring mounting system of U bolts and clamps that provide lower operating stress and increased product durability.

The fact that York has ended 2012 in such a strong position is testimony to our hard working engineering and sales teams across the globe, as well as the fantastic feedback we receive from our highly valued customers. I firmly believe that 2013 will be an even better year and I look forward to working with York's teams and our customers across the globe as we grow our market leading position to a stronger future.



Mr P V Balasubramaniam
Chief Executive Officer

I REMAIN COMMITTED TO STRENGTHENING YORK'S GLOBAL POSITION AND ENSURING THE BUSINESS CONTINUES TO GROW. I LOOK FORWARD TO VISITING MORE COUNTRIES AND CUSTOMERS IN THE FUTURE, TO ENSURE YORK'S GLOBAL BRAND REMAINS STRONG.

INSIDE THIS ISSUE

- 2 Engineering
- 3 Asia
- 4 Australia
- 6 India
- 7 South Africa
- 8 Thailand

MINIMUM COST, MAXIMUM PERFORMANCE

York Transport Equipment's new 25 tonne axle has been engineered with minimum total life cycle cost in mind, to provide our customers with the best of reliability and cost efficiency.

The axle's features have been integrated to keep in mind the heavy-duty loading requirements of York's growing customer base across the world. For example, the reinforced beam (150 mm x 210 mm) has been proven to reduce stress levels and deflections, while the bigger and wider bearings ensure a higher load capacity and increased axle life thanks to York's unique self-retaining design.

Braking has been improved as well. This is because York's 'Q' type cast brake shoe, with a diameter of 460 mm and 177 mm width, outperforms the more conventional 'P' type shoes that come with a smaller 420 mm diameter.

Another impressive York innovation is found in the form of the cleverly designed lubrication system that makes hub greasing possible without opening the hub. The benefit of this is noticeable immediately through longer bearing life.

Other features of the new axle include:

- Out-Board drum for ease of assembly and maintenance
- Built provision for tyre inflation system, reducing fuel consumption and tyre damages while enhancing road safety
- The wheel end is suitable for R25 wheel rim with 10 holes of M27 stud on 335 PCD

With an enhanced payload capacity of 25 tonnes, this premium axle has been tested and evaluated by York's skilled engineering team. A combination of York's virtual simulation of various load conditions and comprehensive fatigue analysis makes this the heavy-duty axle of choice.



A COMBINATION OF YORK'S VIRTUAL SIMULATION OF VARIOUS LOAD CONDITIONS AND COMPREHENSIVE FATIGUE ANALYSIS MAKES THIS THE HEAVY-DUTY AXLE OF CHOICE.

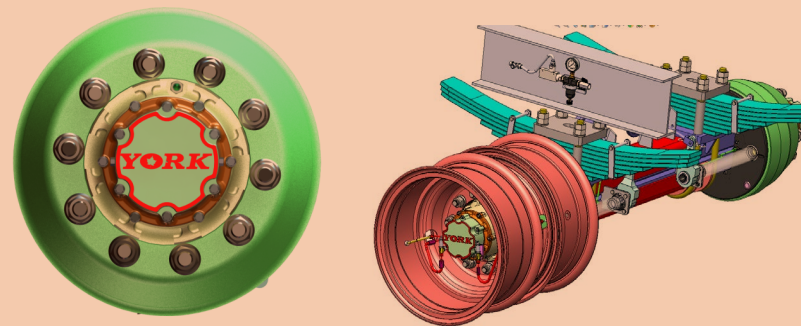

York's new 25 tonne heavy-duty outboard axle.

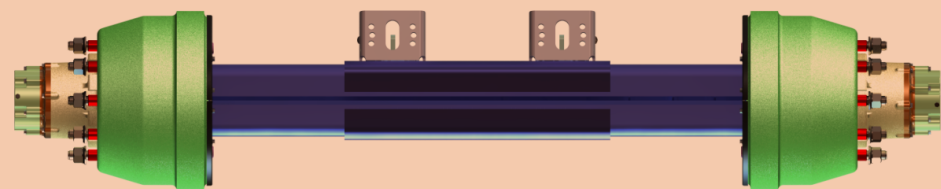

SHINING AT LIANGSHAN

York has perfectly presented its best attributes at the Liangshan Special Vehicle Show 2012.

The Liangshan show, which ran from 17-19 September 2012, brought together more than 300 professional trailer makers – representing huge opportunities and great potential in the developing Chinese market.

York displayed its 5015 and 2011 drum axles, disc axles, mechanical and Tecair II air suspensions, as well as York landing legs. A combination of quality products, professional staff and a well-decorated booth attracted many visitors.

"A lot of trailer component manufacturers have been coming to set up service offices in droves, in order to offer components for the Liangshan market," said Ms Eunice Sun, Customer Service Executive, York Transport Equipment (Asia) Pty Ltd.

"We are confident that our presence at the show will prove helpful in promoting the York brand in Liangshan and give a better understanding of what York is able to offer. Developing a good brand image is vital in China and we are working hard to do just that," Ms Sun said.

"DEVELOPING A GOOD BRAND IMAGE IS VITAL IN CHINA AND WE ARE WORKING HARD TO DO JUST THAT."



York's presence at Liangshan will help establish the York name in the growing Chinese market.

YORK SOON BECOMES NUMBER ONE

Singapore's Soon Wing Trailers has been making its mark for 30 years, all with a little bit of help from York

Soon Wing Trailers Pty Ltd has been in business since 1982, designing and manufacturing a wide variety of specialty and niche trailers for local and overseas customers alike. It has also partnered with the big names of the European heavy truck industry, including DAF, MAN, Mercedes and Scania.

While those names certainly comprise an impressive list, Soon Wing's numbers make equally impressive reading, with over 5,500 trailers manufactured. Exports have proven particularly popular in the ASEAN countries, such as Vietnam, Indonesia, Brunei, Cambodia and the Philippines, with the Soon Wing brand (the only trailer with a Trade Mark Logo registered in Singapore) even spotted as far afield as Kuwait, Africa and South America.

It seems that at least part of the Soon Wing success story can be put down to the fact that the company has been working with York for more than 20 years.

"York's product is suitable for rough terrain and heavy duty usage. It has been reliable and problem free for my export business," said Mr Melvin Wong, Soon Wing Trailer's owner.

"Our customers are satisfied with York's product performance. The positive feedback we are hearing is that York's products guarantee a mixture of low down time and low maintenance costs."

With Soon Wing expanding their manufacturing facility to the nearby Malaysian state of Johor expect this success story to grow and grow.

"OUR CUSTOMERS ARE SATISFIED WITH YORK'S PRODUCT PERFORMANCE. THE POSITIVE FEEDBACK WE ARE HEARING IS THAT YORK'S PRODUCTS GUARANTEE A MIXTURE OF LOW DOWN TIME AND LOW MAINTENANCE COSTS."



Specialist quality: Soon Wing Trailers' reputation as a builder of niche trailers makes it the ideal choice in many countries.

VALUE FOR MONEY

York's Maintenance Free Long life axle range is proving its worth in Australia's mining sector thanks to a relationship that's been 20 years in the making.

McAleese Resources (formerly known as International Energy Services) is one of Australia's leading providers of transport logistics services to the petroleum, LPG, aviation and chemicals industries in Australia and Singapore, as well as a leading provider of transport logistics services to the resources sector in Australia.

As part of servicing the resources sectors, McAleese Resources recently purchased 17 side tipper quad road train combinations to cart valuable iron ore payload from the huge mines of Western Australia to ships waiting in Port Hedland on Australia's north-west coast. These spectacular and uniquely Australian combinations, built by local trailer experts Howard Porter and Kennedy Trailers, have all been made fit for the tough job with York spring leaf suspensions and unitised disc brake axles.

Alan Yates is the Group Asset Manager at McAleese Resources. Mr Yates has been with the company for 29 years, having started out as a driver before working his way up the management chain and eventually finding his niche in fleet management in 1998. According to Mr Yates, McAleese Resources values York's combination of strong commitment to service and price and its tare weight competitive advantages.

"These are the main factors we look for in the mining sector when deciding on a supplier, simply because of the tough loads we're carting and the harsh environment we work in," Mr Yates said.

"We trialled York in the resources division two years ago and it has proven to be a very reliable product. Plus across the whole company we have a strong relationship with York that's gone

back 20 odd years now. We're very comfortable working with York."

The disc brake axles are part of York Australia's MLF (Maintenance Free Long life) axle range. One of the distinguishing features of the 11 tonne capacity MLF axles, which are also available in a drum brake variant, is the special bearing system. The bearing pairs are pre-packaged in a closed dust-free environment and manufactured with a double sealed configuration to protect the bearing package from dusty environments, water and external contamination. This makes the MLF axle more reliable than its competitors for longer life maintenance free application, even in the sort of unforgiving conditions that McAleese Resources specialise in. 

WE TRIALLED YORK IN THE RESOURCES DIVISION TWO YEARS AGO AND IT'S PROVEN TO BE A VERY RELIABLE PRODUCT... WE'RE VERY COMFORTABLE WORKING WITH YORK.



McAleese Resources recently purchased 17 side tipper quad road train combinations, to cart valuable iron ore payload from the huge mines of Western Australia.

NEW PRODUCT INTRODUCTION MFL - MAINTENANCE FREE LONG LIFE AXLE

YORK TRANSPORT EQUIPMENT HAS DEVELOPED A NEW VARIANT TO THEIR PRODUCT LINE FOR AN 11TONNE CAPACITY AXLE CALLED THE MFL AXLE.

THE MAINTENANCE FREE LONG-LIFE AXLE WITH DRUM AND DISK BRAKE VARIANT IS SPECIALLY BUILT TO SUIT THE REQUIREMENTS OF THE AUSTRALIAN MARKET.

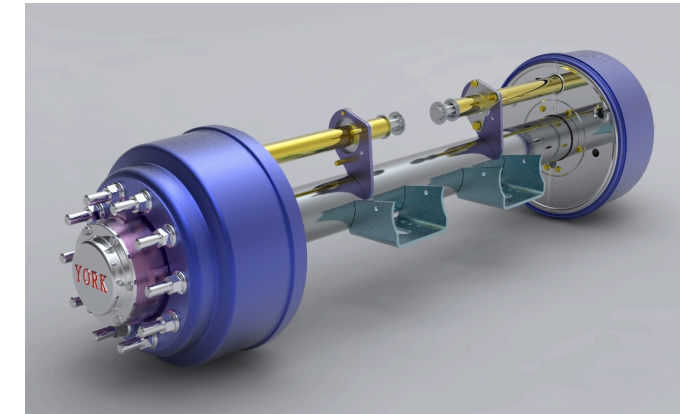

This product has the following salient features:

- 5" round high tensile seamless steel tube with no greasing or servicing required for its entire life cycle operation.
- Bearing pairs undergo a controlled assembly process for improved performance and enhanced expected service life. This meticulous process even includes packaging in a dust free environment to achieve zero contamination
- Durable and unmatched performance of these MFL axles with a positive locking system. Out board drum to suit 10 x 285 and 335 PCD-M22 wheel stud. Per American standard wheel rims.
- Fitted with ADR approved 420 x 180 drum brake or 430mm Disc Wabco twin caliper disk brake (PAN22 model).
- These products are supported by the York product support group. Three (3) years or one million Kms warranty whichever comes earlier.
- Increased uptime. Longer operating hours on the road. Ease of assembly and maintenance.

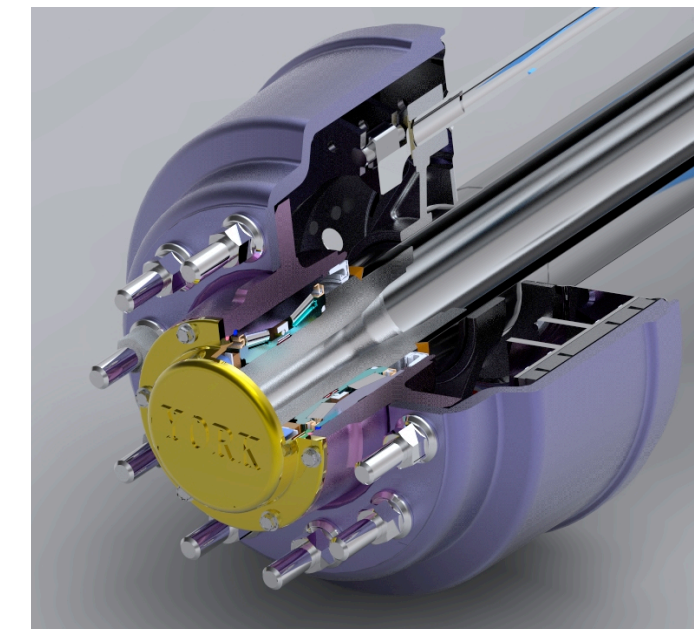

York Australia's MLF (Maintenance Free Long life) axle.

Designed with a double sealed configuration to protect the bearing package from dusty environments, water and external contamination. The product is expected to be more reliable for longer life maintenance free application even in high dust environments like mines and half highways.

SEAMLESS PERFECTION.

Seamless Autotech Pvt. Ltd., one of India's finest and largest manufacturers, has long relied on York's quality equipment. Its mission? To make sure its customers get the best truck and trailer products possible.



Mr Ahluwalia believes that Seamless' key difference in the transport industry is an uncompromising commitment to quality.

Seamless Autotech is practically an Indian institution. As a renowned manufacturer of car carriers (TR-10, TR-8/9, TK- 5/6, TK-1), chassis carriers, flat bed and skeletal trailers, as well as a full range of tippers, the trailer builder puts all of its 15 years' experience into each and every build.

Indeed, a quest for superior quality, reliability and rapid build times has seen the funding of an extensive R&D facility and its consequent integration as a core component of the Seamless world-class fabrication facility.

"Our products and services are characterised by unparalleled quality," said Mr J S Ahluwalia, Chairman and Managing Director of Seamless Autotech, an organisation whose core values are based on honesty, devotion towards work and delivering on promises.

"Along with our R&D centre, our fabrication facility is equipped with state-of-the-art machinery and equipment, a fabrication shop, press shop, dedicated bays for painting, storage and stacking, a short blasting booth, and independent power supply transformers. This ensures that for our clients even their bulk and urgent requirements are duly met."

With the aim of being the leading single source of innovative automobile body building solutions, Seamless Autotech was established in 1996 in Chakan, Pune. Back then just a single production line ran off a range of tippers, flatbeds and containers. In 2010, Seamless added an additional production unit in Talegaon, to cope with increasing demand. Today Seamless boasts a combined trailer production capacity of more than 250 trailers a month, with both plants spread across an area of 250,000 square feet.

Mr Ahluwalia has been instrumental in Seamless' evolution as a trailer builder par excellence and has played a pivotal role in the company's growth to become one of India's premier manufacturers. In an organisation where quality is considered of paramount importance across all its operations, York's axles, suspensions and other trailer accessories are a staple part of Seamless's products, with the relationship with York going right back the company's early days.

"Seamless's competency lies in its customised trailer/truck solutions that suit the customer's operation, regardless of their requirement. From the largest car carrier to the smallest utility van, the fine craftsmanship is never compromised," said Mr G S Chatterjee, COO, York Transport Equipment (India) Pty Ltd.

And as Mr Ahluwalia explained, Seamless Autotech's trailers and truck bodies have withstood the test of time thanks to this emphasis on the most trusted and genuine parts.

The factor which sets Seamless apart from the competition is genuine material used with test certificates," Mr Chatterjee added.

"That's why York, with our uncompromising commitment to quality, has been the obvious choice for Seamless. In a competitive yet still young industry, Seamless and York are making a commendable effort to build a more structured and efficient industry in every possible way."

"THE FACTOR WHICH SETS SEAMLESS APART FROM THE COMPETITION IS GENUINE MATERIAL USED."



FAMILY FIRST

South Africa's Martin Trailer Company is living proof that you don't have to be the biggest to be the best.

Established in 1984, Martin Trailer Company manufactures a full range of lowbed, tilting platform, flatbed and skeletal trailers, as well as specialised and custom built trailers for both on- and off-highway applications.

Martin Trailer Company is a family-owned and run business that understands the value of strong customer relationships, integrity and respect in all its dealings. When you add in a commitment to research and development, great engineering skills, and after sales support, it quickly becomes clear how the Martin family became leaders in the field of heavy-duty trailer manufacturing.

"From its humble beginnings in 1984 with only ten employees serving its loyal customers, Martin Trailer Company now leads the way in heavy-duty commercial trailers and tow-behind compaction equipment in the African market.

They have also expanded their sales and service internationally," said Mr Christo Els, York's Sales Executive – Southern Africa.

York South Africa supplies Martin Trailer Company with axles and suspensions for these international orders outside South Africa, including the York RO8 bogie axles.

"The trailers with the York bogie axles were exported to Australia and Namibia. We've also supplied York lowbed axles to Martin Trailer Company for an order to Siberia, with the customers preferring York over other well known brands. Additional spare parts were supplied with each axle order to prevent any technical or spare shortages and we'll be looking into continuing to serve this customer in the future," Mr Els said.

Martin Trailer Company capacities range from 20 tonnes to over 400 tonnes, carrying both specialised equipment as well as general cargo. Most of these products and services are supplied to the mining, construction, transport, plant hire and agricultural industries. Martin Trailer Company also offers fully equipped facilities for servicing and repairing trailers for these industries.

"WE'VE ALSO SUPPLIED YORK LOWBED AXLES TO MARTIN TRAILER COMPANY FOR AN ORDER TO SIBERIA, WITH THE CUSTOMERS PREFERRING YORK OVER OTHER WELL KNOWN BRANDS."



From South Africa to Siberia: Martin Trailer Company has the world covered.

NOTHING BUT THE BEST

With more than 25 years of trailer building experience, Au Peak Co – with a helping hand from York – has become a mainstay of the Thailand transport industry.

Au Peak Co is recognised in Thailand for its main speciality – producing quality bottom dump trailers with a reputation for standing up to the harsh rigours of life on the road in Thailand. The company's owner, Mr Peak, has chosen original York axles since his first trailer rolled off the production line a quarter of a century ago.

"To this day Mr Peak continues to recommend York axles to every one of his many customers when they order a new Au Peak Co trailer. Considering how long Mr Peak has been in business, that's an incredible compliment for York," said Mr Siam Tanon, Assistant Manager Sales, York Sales (Thailand).

"The reason Mr Peak prefers York is really quite simple: the quality of York equipment makes it a trusted brand in the Thailand transport industry. And one thing is certain, Mr Peak does not believe in using imitations. Customers in Thailand will only accept original York equipment."

"THE REASON MR PEAK PREFERS YORK IS REALLY QUITE SIMPLE: THE QUALITY OF YORK EQUIPMENT MAKES IT A TRUSTED BRAND IN THE THAILAND TRANSPORT INDUSTRY."



Au Peak Co's colourful trailers are well known on Thailand's roads.

York Contacts

Australia

13 Monterey Road Dandenong,
Victoria 3175 Australia.
T: +61 3 9790 2000
F: +61 3 9790 2020
C: Mr Phillip Craker
E: phillip.craker@yorktpt.com.sg

China

18 Huishui Road, Licang District,
Qingdao, China 266100
T: +86 400 0088 5755
F: +86 532 80923080
C: Mr Leo Miao
E: leo.miao@yorktpt.com.cn

India

Gat No. 537 & 538
Bhadhalwadi, Navlakh Umbre,
Maval Pune 410507 India
T: +91 92 7220 0726
C: Mr. Pankaj Shenoy
E: pankaj.shenoy@yorktpt.co.in
C: Mr. Gurmukh Singh
E: gurmukh@yorktpt.co.in

Indonesia

C: Frederick Tay
M: (65) 97414993
E: tay.frederick@yorktpt.com.sg

Saudi Arabia

Dammam Saudi Arabia
T: +966 50 490 8315
C: Mr Engr Zulfiqar A Khan
E: thp-extraxuk@btconnect.com
E: zulfiqar.khan@yorktpt.com.sg

Singapore

Corporate & Marketing
122 Pioneer Road Singapore 639583
T: +65 6897 8525
F: +65 6897 8231
C: Frederick Tay
E: tay.frederick@yorktpt.com.sg

South Africa

115 Bellefield Ave Mondeor
Johannesburg 2091 South Africa
T: +27 82 376 4552
C: Mr Willem Brits
C: Christo Els
F: +27 71 889 7407
E: wbrits@yorktpt.co.za

Thailand

2101 M.1 Old Railway Rd
Samrong Nua Muang
Samutprakarn 10270, Thailand
T: +66 2 743 5091
F: +66 2 173 7300
C: Ms Faifun Sodkhomkham
E: yorkth@ksc.th.com

United Kingdom

(Middle East & African Markets)

5 Scott Close Market Harborough
Leicestershire LE16 7LN
United Kingdom
T: +44 1858 434 425
F: +44 1858 465 125
C: Mr Tony Partridge
E: thp-extraxuk@btconnect.com