

Tecair 1

Air Suspension

Installation & Maintenance

For Your Trailer Axle Suspension Needs Call York :

Head Office

Singapore

York Transport Equipment (Asia) Pte. Ltd.

No. 5 Tuas Avenue 6, Singapore 639295

Email : enquiry@yorktpt.com.sg

Tel : (65) 6861 0577

Fax : (65) 6861 4045

Installation Instructions

General Procedure:

As far as design is concerned, specific dimensions together with some recommendations of trailer structures are shown in the following drawings. These show offset airspring installations (tri-axles, tandems or single axles with dual or super single tyres) and the variations of ride height.

For trailers under construction, the supervision installation is ideally carried out with the trailer upside down :

- 1) Weld the airspring pedestals in place and put the airsprings on the chassis.
- 2) Put the center axle of Tri-axle suspension or the front axle of a Tandem suspension in position on the chassis using the bump stops inside the airsprings to take the weight of the axle.
- 3) Move the axle around until it is central on the chassis and aligned to the kingpin within the tolerance shown on the appropriate drawing. Weld in position (weld details are on the installation drawing).
- 4) Assemble the other axle to the chassis and align these to the front or center axle already fitted.
- 5) If, after the suspension has been welded on, it is discovered that it is out of alignment, adjustment is possible as follows – **refer below (alignment procedure)**.
- 6) Fit the bolts securing the airsprings and bottom plates to the plates using Loctite 242 on the threads and torque to 70Nm. **Refer to drawing 506219 (page 5)**.
- 7) Fit axle restraint straps one per inner side of chassis main beam, as described in **(page 12) Installation Procedure**.
- 8) Fit the levelling valve and suspension pneumatics.

Installation Drawings:

790408 – Refer pages 3 & 4 (for 400 ride height)

Note:

All torque settings in this manual are subject to a tolerance of +/- 3% from those specified.

Alignment Procedure:

- 1) Loosen the U-bolts on both sides and then remove them from one side.
On the side where the U-bolts are removed, use a cutting disc to cut the weld between the tracking plate and the axle spring seat.
- 2) Replace the U-bolts and tighten until the axle spring seat contacts the spring.
i.e. the joint is lightly nipped.
- 3) Use a hide mallet or Porta power to move the axle backwards or forward until it is aligned.
Re-torque the U-bolts to 850 Nm (600 lbf ft) and re-check the alignment. Re-adjust the alignment if necessary. **Re-weld the tracking plates.**
- 4) It is most important that the weld between the axle spring seat and tracking plate is checked irrespective of whether re-alignment is necessary.
This weld must be put in place before the suspension enters service.

REV	MODIFICATION	DATE	DRN/CHKD	EAR
A	FIRST ISSUE	22-06-00	SITI/FEI	00055

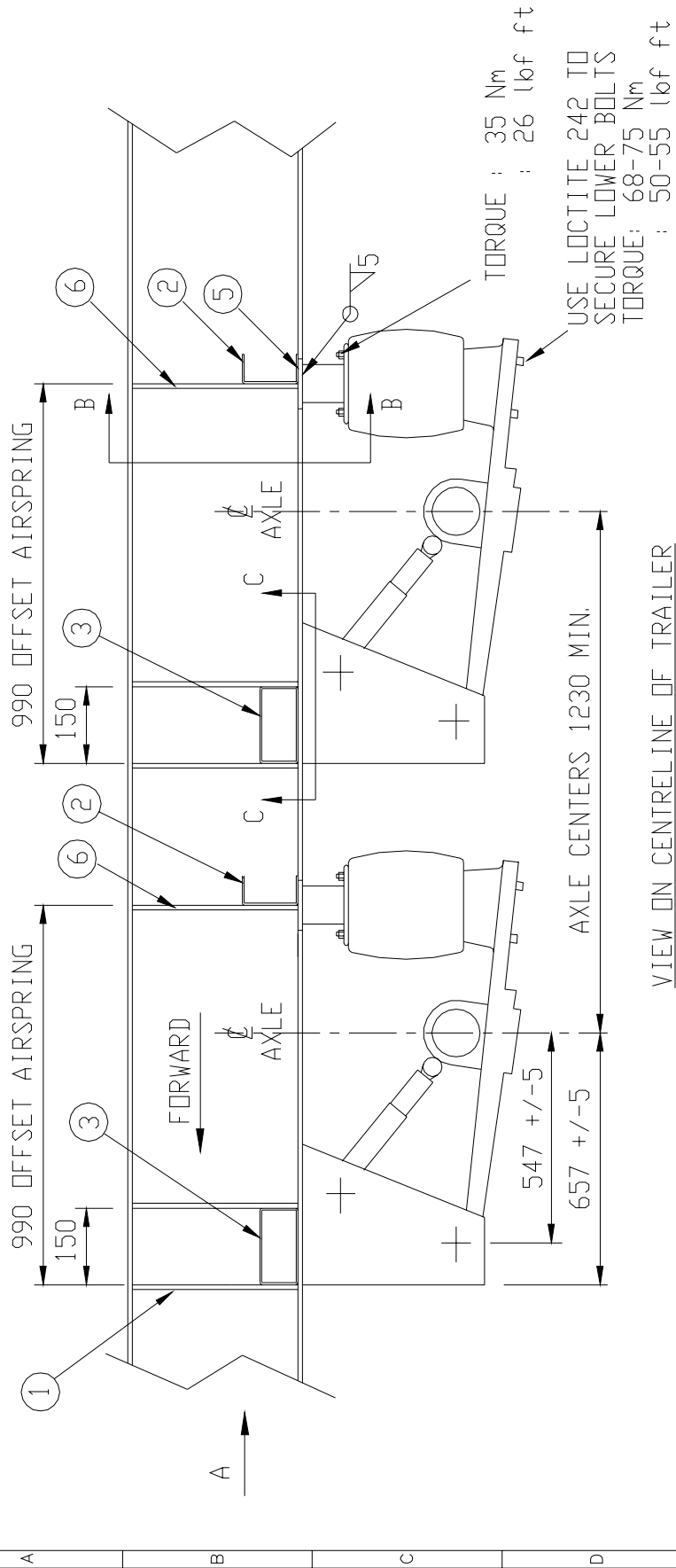

VIEW ON CENTRELINE OF TRAILER

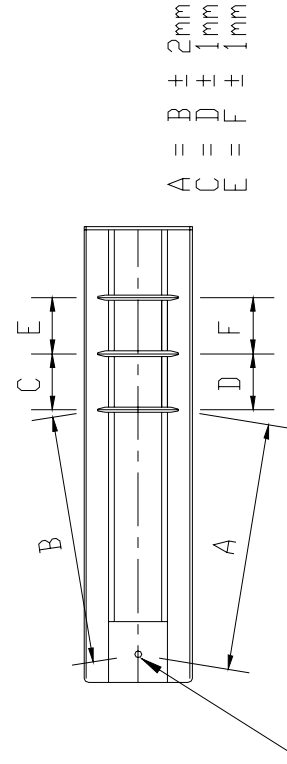

- A = B ± 2mm
- C = D ± 1mm
- E = F ± 1mm

YORK TRANSPORT EQUIPMENT (ASIA) Pte. Ltd.				
EAR NO	00055	MATERIAL		
DRAWN BY	SITI	TITLE		
CHECKED BY	FEI	TECAIR 1 - OFFSET AIRBAGS INSTALLATION RECOMMENDATIONS		
APPROVED	BMM	400 RIDE HEIGHT		
DATE	22-06-00	DRG. NO.	790408	REV.
				1 OF 2

COPYRIGHT © 2000 YORK TRANSPORT EQUIPMENT (ASIA) PTE. LTD. ALL RIGHTS RESERVED.

1	2	3	4	5	6	7	8
REV		MODIFICATION		DATE		DRN/CHKD	
A		REFER FIRST PAGE		22-06-00		SITI/FEI	
						00055	

NOTE:

- 1) TECAIR SUSPENSIONS ARE SUPPLIED FULLY ASSEMBLED WITH THE AXLES READY ALIGNED TO THE SUSPENSION
- 2) ALL BOLTS AND NUTS ARE TORQUED TO THE CORRECT SETTING, EXCEPT THE AIRSPRING FITTINGS WHICH ARE SUPPLIED LOOSE
- 3) THE TRACKING PLATES ARE SUPPLIED READY WELDED SO THE SUSPENSION UNIT MUST BE ALIGNED TO THE KINGPIN WHEN MOUNTED ON THE MAINRAILS OR TO THE SUBFRAME ON VANS
- 4) WITH FLANGES LESS THAN 130mm WIDE FURTHER SUPPORT IS REQUIRED FOR THE FRONT HANGERS (SEE SECTION C-C)
- 5) HANGER & AIRBAG CROSSMEMBERS (ITEMS 2 & 3) ARE SHOWN MOUNTED FLUSH WITH THE TOP OF THE BOTTOM FLANGE, THESE CROSSMEMBERS CAN BE MOUNTED FLUSH BELOW OR ABOVE THE FLANGE AS REQUIRED
- 6) PLEASE REFER TO EACH TECAIR 1 SUSPENSION DRAWING FOR SPRING CENTER SUITABLE FOR DIFFERENT TYRE. THE SPRING CENTER CALCULATION IS BASED ON $DIM 'W' \leq 165mm$.
CHECK WITH YORK ENGINEERING WHEN $DIM 'W' > 165$.

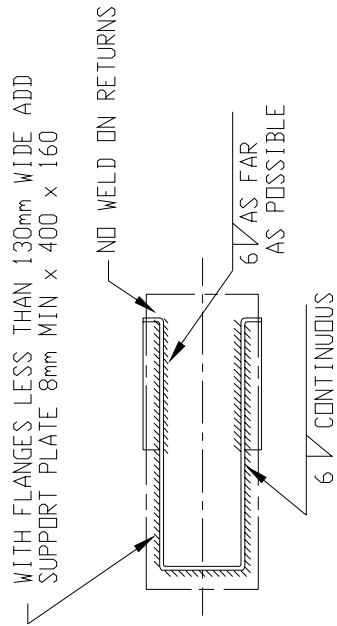
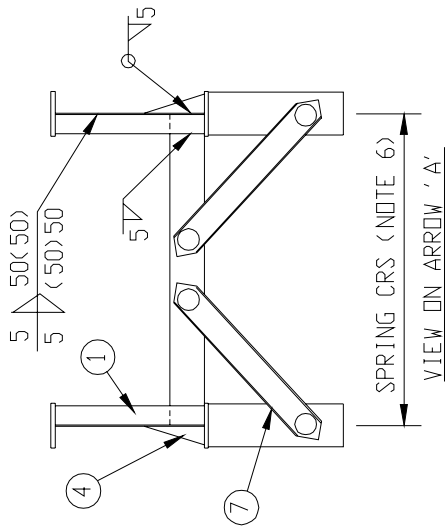
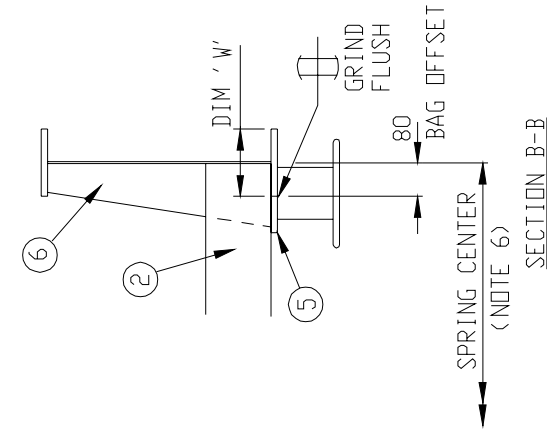

7	CROSS BRACE - 506301/04
6	GUSSET 10mm THICK MINIMUM
5	PEDESTAL PLATE - 506196
4	OUTER STIFFENER
3	RHS 150 x 100 x 5 MINIMUM
2	RSC 127 x 64 MINIMUM
1	WEB STIFFENER 10mm THICK MINIMUM
ITEM	DESCRIPTION

YORK TRANSPORT EQUIPMENT (ASIA) Pte. Ltd.	
EAR NO	MATERIAL
00055	
DRAWN BY	TITLE
SITI	TECAIR 1 - OFFSET AIRBAGS
CHECKED BY	INSTALLATION RECOMMENDATIONS
FEI	400 RIDE HEIGHT
APPROVED	BMM
DATE	DRG. NDL.
22-06-00	790408
	SHEET
	2 OF 2
	REV. A

COPYRIGHT © 2000 YORK TRANSPORT EQUIPMENT (ASIA) PTE. LTD. ALL RIGHTS RESERVED.

1	2	3	4	5	6	7	8
REV		MODIFICATION		DATE		DRN/CHKD	
C		ITEM 1 WAS HB12/175/030		13-06-00		S1T1/FEL	
						E AR	
						00050	

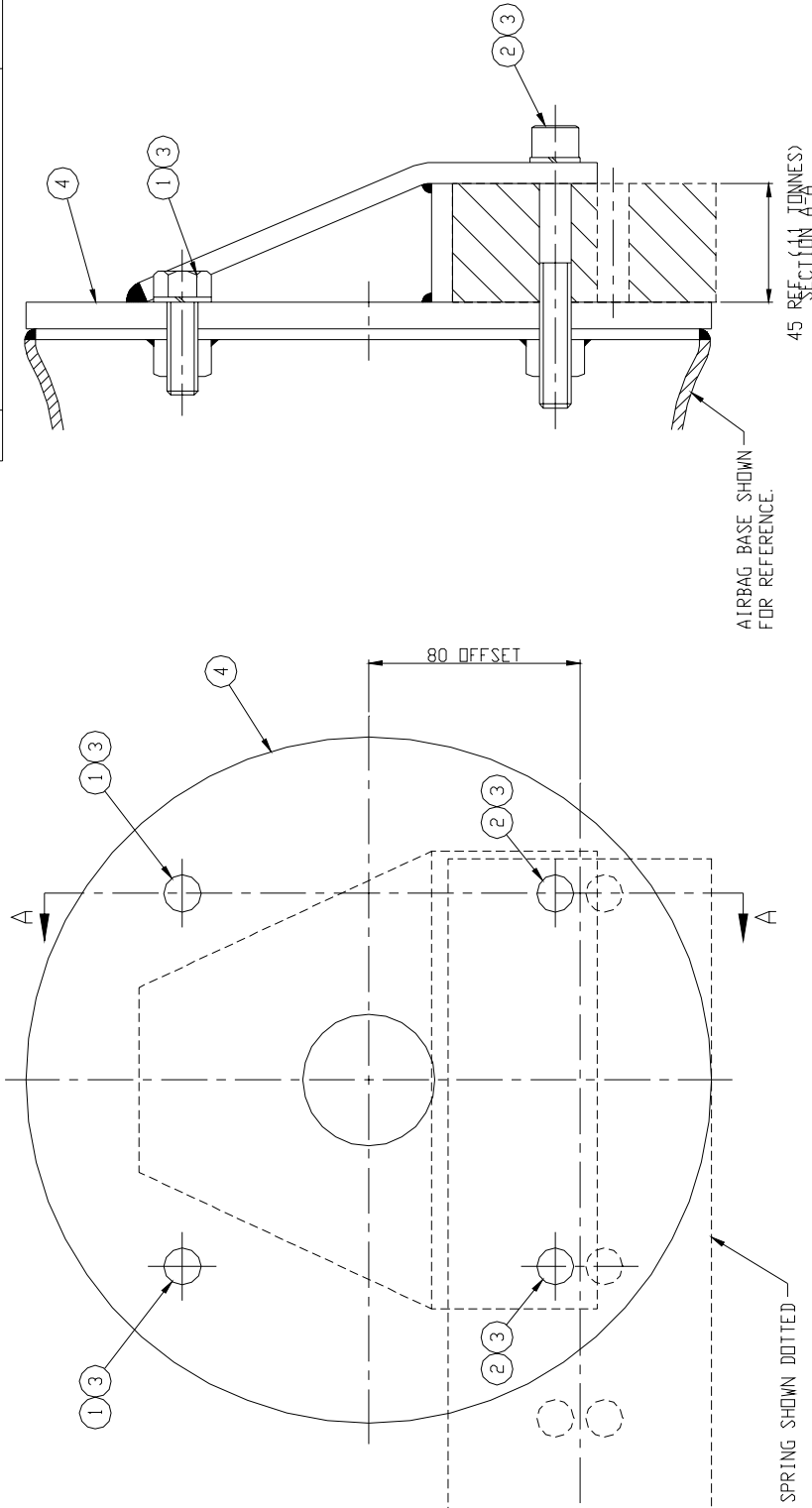

NOTE

- 1) AIRSPRING REINFORCEMENT PLATES & AIRBAGS ARE TO BE FITTED 'LEFT' & 'RIGHT' HAND TO PROVIDE CORRECT OFFSET FOR INSTALLATION OF AIRBAGS.
- 2) FIT AIRBAG REINFORCEMENT PLATE TO SPRING END, THEN FIT AIRBAG BOTTOM USING ITEMS 1, 2 & 3.
- 3) TORQUE ALL FITTINGS TO 70Nm.
APPLY LOCTITE 242 TO THREADS.

ASSEMBLY PARTS LISTING (QTY PER AXLE MIDDLE)			
ITEM	PART NO.	QTY.	DESCRIPTION
1	HB12/175/040	4	M12 x 1.75 x 40 LONG HEX. BOLT
2	CB12/175/100	4	M12 x 1.75 x 100 LONG CAP HEX. BOLT
3	SW12	8	M12 SPRING WASHER
4	506220	2	AIRBAG REINFORCING PLATE

YORK TRANSPORT EQUIPMENT Pty. Ltd.	
EAR NO.	96516
MATERIAL	IMA
TITLE	INSTALLATION OF 80mm OFFSET AIRBAG MOUNTING PLATE TO TECAIR 1
DRAWN BY	FET
CHECKED BY	BMM
APPROVED	
DATE	18-07-96
DRG NO.	506219
REV.	SHEET
1	1 OF 1
C	C

COPYRIGHT © 1996 YORK TRANSPORT EQUIPMENT PTY. LTD. ALL RIGHTS RESERVED.

Procedure for Setting of Height Control Leveling Valve

There are two methods for setting leveling valves:

- 1) If the valve is being set by the trailer manufacturer, then this is best achieved without use of air in the system. Preferably with the trailer inverted with the axle resting on the airspring bump stops.
 - a) Adjust the leveling valve arm to a 225mm radius ensuring that the arm enters through the side of the boss marked "V" and lock the quadrant in the neutral position by inserting a 4mm-drill shank through one of the holes provided.
 - b) Lift the axle to the ride height required and connect the leveling valve link to a bracket attached to the axle. Remove drill shanks before releasing axle.
On no account must the spacers be welded to the axle beam to maintain axle ride height while the leveling valve is being set.
- 2) If for any reason the valve is being set at a later stage, then the following procedure may be used:
 - a) Put the trailer on even ground, preferably with the vehicle laden and with a prime mover under the front. Air reservoirs to be fully pressurized and hand brake, if fitted must be released for safety reasons.
 - b) Exhaust air bags by turning valve arms downward to deflate airsprings.
 - c) Open valve and raise suspension to ride height by turning lever upwards, insert 4mm drill shanks or dowels into holes provided to lock arm in neutral position.
 - d) Attach rod of required length to axle bracket with the lever radius operating on a 225mm radius.

Once set, the ride height may be finely adjusted using the rod adjustment nut on the lower rod linkage.

1	2	3	4	5	6	7	8
REV		MODIFICATION		DATE		DRN/CHKD EAR	
B		INSTALLATION NOTES REVIEWED		01-08-00		S111/FE1 00061	

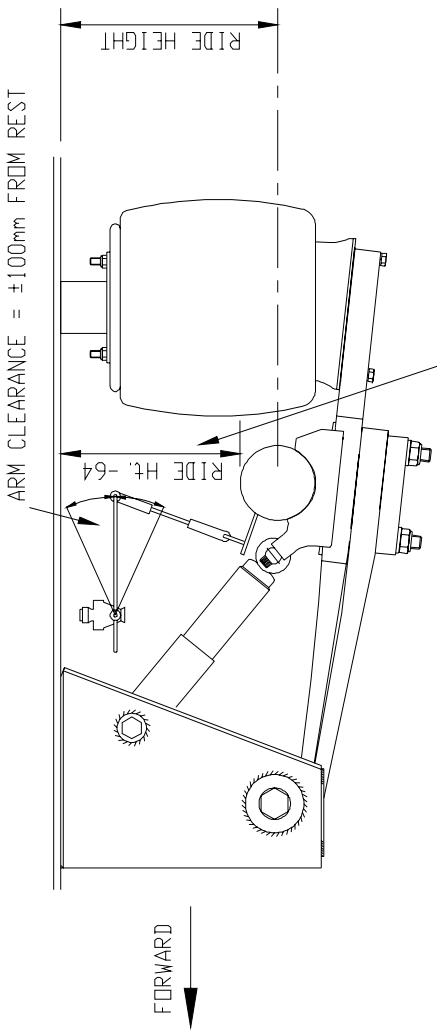

USE THIS DIMENSION FOR SETTING THE RIDE HEIGHT

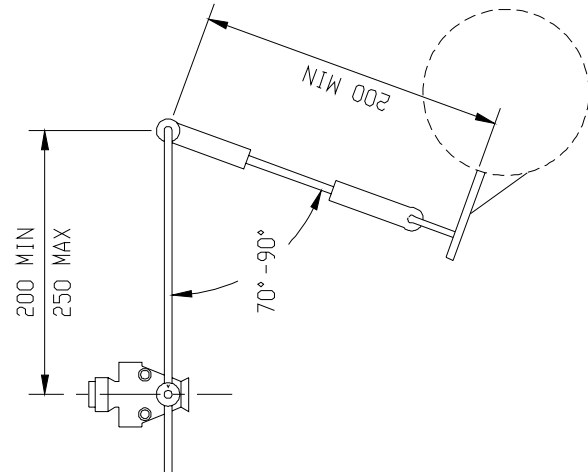

B INSTALLING LEVELLING VALVES:

- 1) THE LEVELLING VALVE MUST BE FITTED TO THE MIDDLE AXLE ON A TRI-AXLE TRAILER AND IS USUALLY FITTED TO THE REAR AXLE ON A TANDEM. IN CASE OF DRAWBAR TRAILER, TWO LEVELLING VALVES ARE REQUIRED (ONE FOR EACH AXLE GROUP).
- 2) ON COMPLETION OF THIS ADJUSTMENT, ENSURE THAT THE ARMS ARE SIMILAR TO THE DRAWINGS, IN DIMENSIONS AND ANGLES. THIS WILL THEN GIVE CORRECT OPERATION AND WITH THE AXLE TRAVEL ARMS WILL NOT GO OVER CENTER CREATING REVERSE OPERATION OF THE LEVELLING VALVE CONTROL ARM.
- 3) TO ESTABLISH THE CORRECT RIDE HEIGHT, CHECK THE TECAIR SERIAL NUMBER PLATE WHICH IS RIVETED TO ONE OF THE FRONT SUSPENSION HANGER BRACKETS. e.g. TA1/11/400. IN THIS CASE - THE RIDE HEIGHT IS 400mm.
 - a) HAVE THE TRAILER ON LEVEL GROUND PREFERABLY LOADED AND WITH PRIME MOVER ATTACHED.
 - b) AIR RESERVOIRS SHOULD ALL BE FULLY CHARGED AND TESTS SHOULD BE PERFORMED WITH THE ENGINE RUNNING ENSURING ADEQUATE AIR SUPPLY.
 - c) BRAKES MUST BE OFF. (NO BRAKES)
 - d) LOOSEN THE CLAMPS ON THE VERTICAL ADJUSTING ROD. ALTER THE LENGTH OF THE ROD UNTIL THE CORRECT RIDE HEIGHT IS OBTAINED. SHORTEN TO LOWER - LENGTHEN TO RAISE. RE-CLAMP THE ADJUSTING ROD.

EAR NO.		MATERIAL	
DRAWN BY		TITLE	
EDS		TECAIR 1	
CHECKED BY		PNEUMATIC INSTALLATION	
BMM			
APPROVED		BMM	
DATE		DRG NO.	
		786809	
REV.		SHEET	
B		1 OF 1	

YORK TRANSPORT EQUIPMENT Pty. Ltd.

COPYRIGHT © 1990 YDRK TRANSPORT EQUIPMENT PTY. LTD. ALL RIGHTS RESERVED.

Maintenance

Tecair is a very robust air suspension. Misuse or neglect should result in rapid breakdown or failure. By observing the servicing and operating requirements laid down below, it should be possible to extend the trouble-free operation of the suspension by years.

Operation:

Before moving the trailer, ensure that the suspension is inflated. The quick check for inflation is that, some piston is showing beneath the rubber diaphragm of the airspring. If this is not the case, couple the prime mover air lines, and run the engine for a few minutes and re-checks. If the suspension still will not inflate, **refer to “Fault Finding” - (Page 9).**

In the event of the suspension deflating while the vehicle is travelling, the bump stops inside the airsprings will carry the load. However, because of the slope of the trailer, the rear axle will carry nearly all the load. Therefore, it is possible to continue to a point where repairs can be to the extreme but the journey must be at a slow speed to avoid further damage to the rear tyre.

Servicing Intervals:

After 500km	Tighten U-bolts and pivot bolts to torque settings shown on data sheet 786810. (refer page 11 and Note below)
After 5,000km	Tighten all suspension bolts to torque settings shown on data sheet 786810. (refer page 11 and Note below)
Quarterly or Every 25,000km	a) Tighten all suspension bolts to torque settings shown on data sheet 786810 (refer page 11) . Inspect shock absorbers for oil leakage, replace if necessary. b) Inspect shock absorber bushes, replace if necessary. c) Check axle alignment for pivot bush wear out. d) Drain air tanks and jack up trailer until airspring is at full stretch. Check rubber for signs of perishing, remove any debris which has collected between the diaphragm and the piston.
Annually or Every 100,000km	a) Remove pivot bolts and lower front of trailer armspring from hanger bracket to permit inspection of pivot bushes and wear pads. It is best to replace pivot bushes without disturbing U-bolts. b) “Leak test” all piping joints and the airspring top plate to diaphragm joint by using “soapy water”. c) Inspect spring leaves for cracks, it is recommended that single leaf suspension springs are crack tested annually after five years of service. d) Repeat quarterly checks.

Note:

It is extremely important to tighten U-bolt and pivot bolt nuts and other nuts to torque setting at first 500km and first 5000km for prolonged service life.

Fault Finding

This section covers fault finding in the basic pneumatic system:

1) *Suspension will not inflate:*

- a) Check for dump valves and if fitted, ensure it is in the “raise” position.
- b) Check that the levelling valve has not become disconnected.
- c) Check very carefully for air leaks.
- d) Check that there is air in the suspension tank by unseating its drain valve.
If there is little or no pressure, check that the brake tank has sufficient pressure.

**REMEMBER THAT THE PRESSURE GAUGE IN THE PRIME MOVER DOES NOT
SHOW THE PRESSURE IN THE TRAILER TANKS**

If there is no leakage and there is pressure in the brake tank, two possibilities exist:

- Either
- a) The compressor on the prime mover is incapable of providing significant output above the 6 bar required, to make air flow through the pressure protection valve to the air suspension tank or
 - b) The pressure protection valve has malfunctioned.
Before replacing the pressure protection valve, **(never try to adjust a pressure protection valve)** it is advisable to get a new or different prime mover unit and try again.
Finally, if the weather is cold, try warming the pressure protection valve, in case it is damp and has frozen.

If the initial checks on the tank pressures revealed plenty of air in both tanks, then must examine the levelling valve:

Disconnect the link to the axle and tilt the levelling valve arm to 45° (degrees) above the horizontal, if the airsprings still will not inflate, the levelling valve will need to be changed. Again, in cold weather try warming up first.

2) *Suspension inflates one side only:*

With only one levelling valve fitted, this is not possible. If the airspring has this appearance, then one side has a serious leak.

3) *Trailer Bounces Excessively:*

Shock absorbers are worn out and need replacing.

The Following are not Faults:

1) *Trailer suspension deflates while being loaded:*

- a) This occurs because the volume and pressure of air suspension tank is insufficient to inflate the suspension airsprings to their laden pressure.
- b) Load while a prime mover is coupled with its engine running.
- c) Fit an additional suspension air tank to the trailer.

2) *Trailer parked on ramp – suspension deflates:*

This can happen if the axle to which the levelling valve is fitted, to some extent left hanging. The suspension will inflate once the trailer is moved to flatter ground, although deflation may take a few minutes because the levelling valve will have emptied the suspension tank.

Driver Training

Driver should not be expected to maintain or repair Tecair Suspensions but should be trained in the following areas:

i. Use of Raise Lower Valve

By far, the most common cause of failure associated with air suspensions of all types are directly related to misuse of the Raise Lower Valve.

Typically, a Raise Lower Valve has 5 positions:
The valve **must** be in the **central ride position** when the vehicle is in transit. If the trailer is allowed to travel in the 'raise' or 'raise lock' position, the shock absorbers and the airsprings will only avoid damage if cable restraints are fitted and even then, secondary damage may result from the trailer having virtually no suspension. If trailer is allowed to travel in the 'lower' or lower lock' position, the bump stops inside the airsprings and the back axle may be damaged. Proper use of the Raise Lower Valve will be useful in dock levelling for rear end loading and in the workshop, it is an aid to quick wheel removal (i.e. raise the suspension before jacking the frame up).

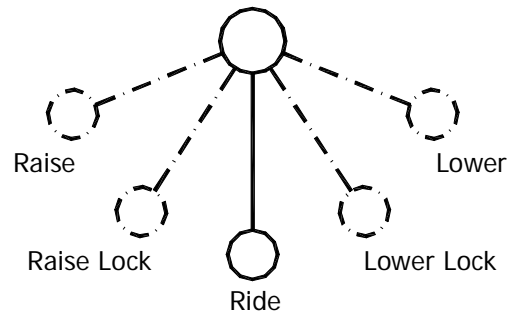

ii. Use of Dump Valve

A Dump Valve has only "ride" and "dump" positions. If trailer is allowed to travel with the valve in the "Dump" position, the rear airsprings and the rear axle will be damaged. If the driver is uncertain of the "ride" and "dump" position, then look at the airsprings and see if there is any piston showing beneath the rubber diaphragm. If there is piston showing, it must be in the "ride" position. If there is no piston showing, it must be in the "dump" position or the suspension may not have had time to inflate. Allow the tractor to charge the trailer for a few more minutes and then re-check.

iii. What to do if an airspring bursts?

Airsprings virtually never burst when in normal use. They may burst, if the Raise Lower Valve has been left on the "raise" position. When the tyre bursts, the disintegrating tyre will cut the airspring. Once the airspring is cut, the entire suspension will deflate. The suspension load, perhaps 20 tones, is now on the back axle. The trailer can still be driven in this condition, but certain restrictions must be applied.

30 km/h maximum speed – reduced to 20 km/h on bad roads

Not more than 100 km in this condition.

If these restrictions are followed closely, the trailer can move to the destination where repairs can take place to avoid further damage.

1	2	3	4	5	6	7	8
REV		MODIFICATION		DATE		DRN/CHKD EAR	
C		PIVOT BOLT - TORQUE WAS 1090 TO 1160Nm		18-02-02		SITI/FEI 02010	

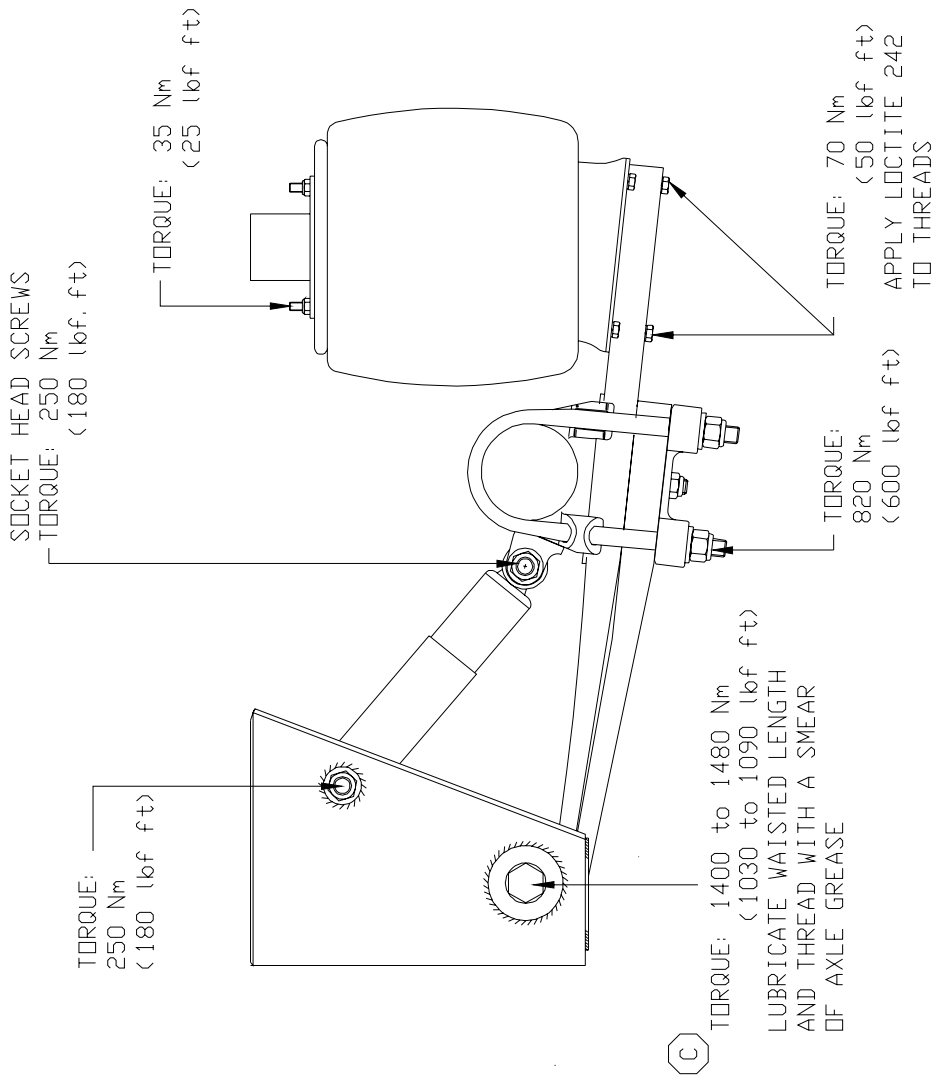

TORQUE AND SETTING DATA
TECAIR 1 SUSPENSIONS

YORK TRANSPORT EQUIPMENT Pty. Ltd.	
EAR NO.	MATERIAL
DRAWN BY	TITLE
CHECKED BY	TECAIR 1 SUSPENSION
APPROVED	TORQUE SETTINGS
DATE	DRG. NO.
01-10-90	786810
SHEET	REV.
1 OF 1	C

COPYRIGHT © 1990 YORK TRANSPORT EQUIPMENT PTY. LTD. ALL RIGHTS RESERVED.

1	2	3	4	5	6	7	8
REV B		MODIFICATION		DATE		DRN/CHKD EAR	
SPRING SEAT DESIGN UPDATED		07-03-00		S111/FEI		00015	

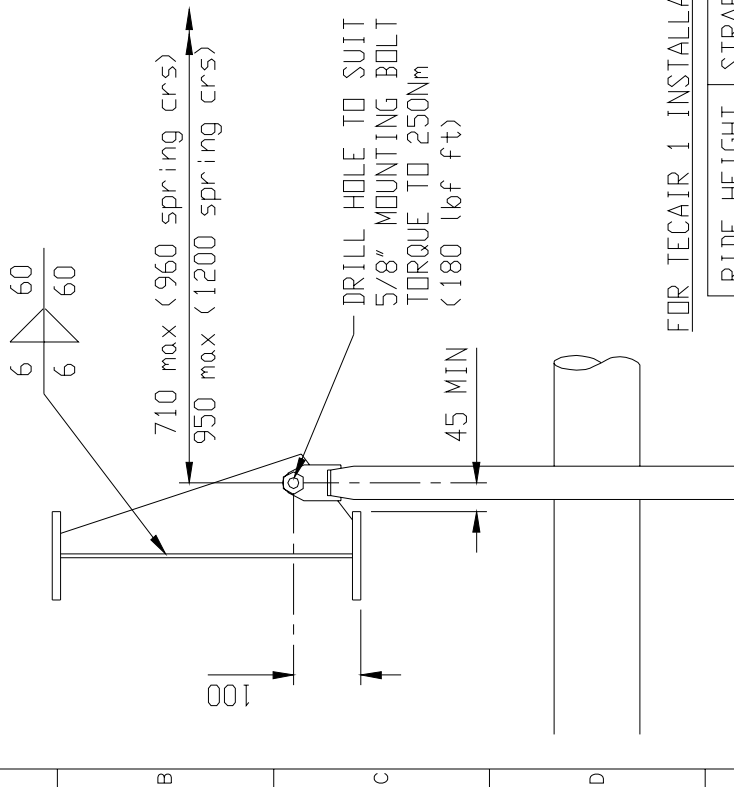
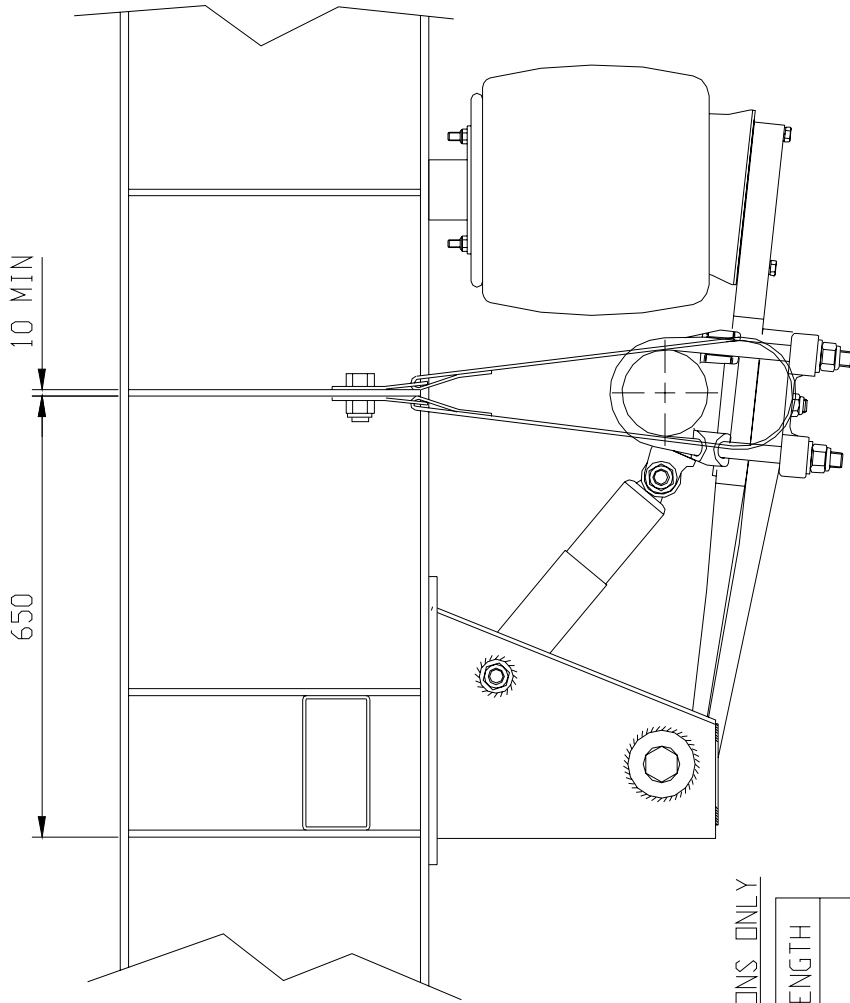

FOR TECAIR 1 INSTALLATIONS ONLY

RIDE HEIGHT	STRAP LENGTH
200	970
300	1170
350	1270
400	1370

NOTE:
 STRAPS ARE TO BE FITTED ONE PER SIDE OF THE TRAILER, INSIDE THE MAINRAILS. CARE SHOULD BE TAKEN DURING INSTALLATION TO ENSURE THE STRAP DOES NOT FOUL WITH ANY CHASSIS, SUSPENSION OR AXLE COMPONENTS.

YORK TRANSPORT EQUIPMENT Pty. Ltd.	
EAR NO.	MATERIAL
DRAWN BY	TITLE
CHECKED BY	AXLE RESTRAINT STRAP
APPROVED	INSTALLATION RECOMMENDATION
DATE	DRG NO.
01-10-90	786807
SHEET	REV.
1 OF 1	B

COPYRIGHT © 1990 YORK TRANSPORT EQUIPMENT PTY. LTD. ALL RIGHTS RESERVED.